



4,6,10 Shooter™

SAEED MULTI-BAND LIGATOR

QUICK REFERENCE GUIDE

PREP 1

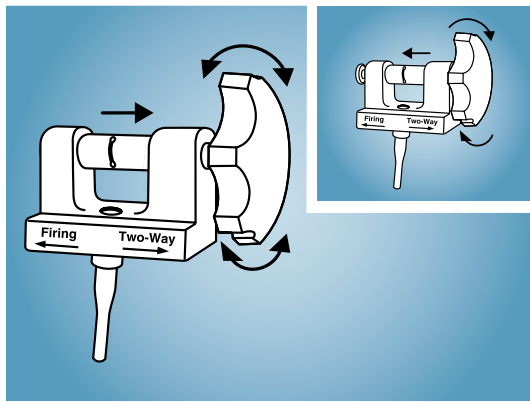

The firing position allows the handle to be rotated in the forward direction only. The **two-way position** allows the handle to rotate in both directions.

PREP 2

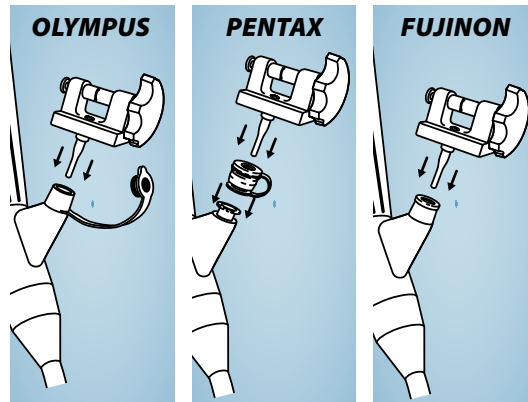

Insert the ligator handle into the endoscope accessory channel.

PREP 3

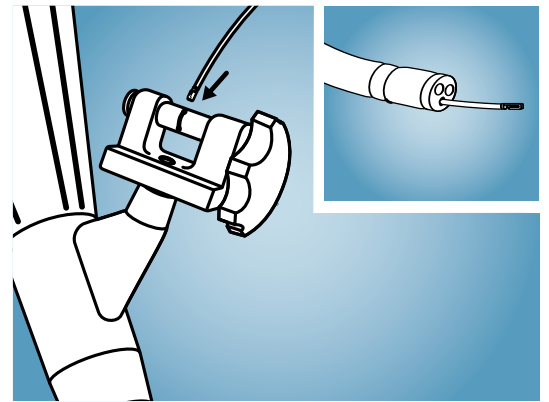

Introduce either end of the loading catheter through the white seal in the ligator handle and advance, in short increments, until it exits the tip of the endoscope.

PREP 4

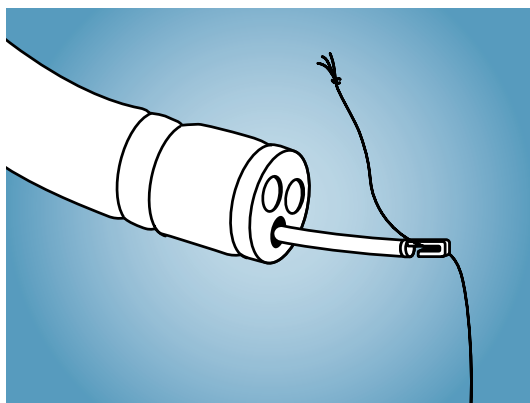

Attach the trigger cord, leaving approximately 2 cm of cord between the knot and the hook. Withdraw the loading catheter and trigger cord up through the endoscope and out through the ligator handle.

PREP 5

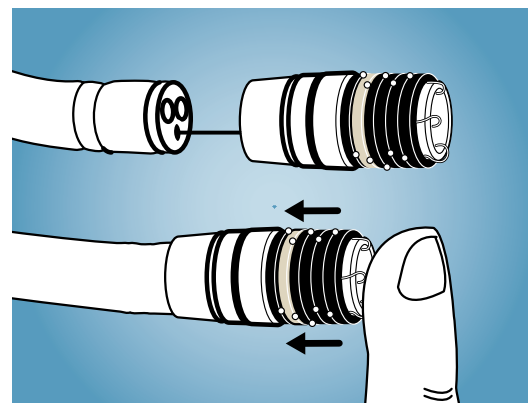

Secure the friction fit adapter of the Opti-Vu® barrel to the tip of the endoscope, advance as far as possible. Avoid bands while pushing.

PREP 6

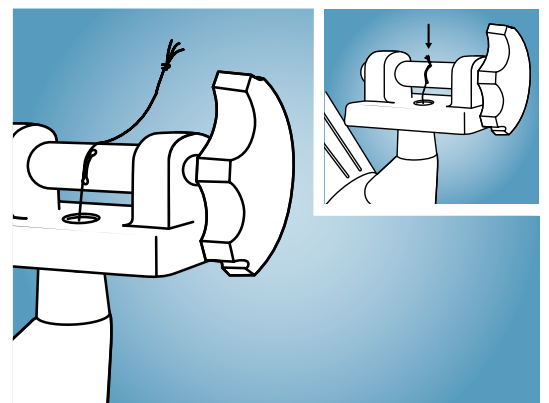

Place the trigger cord into the slot on the spool of the ligator handle and pull down until the knot is seated in the hole of the slot. The knot **must** be seated into the hole for the handle to function properly.

PREP 7

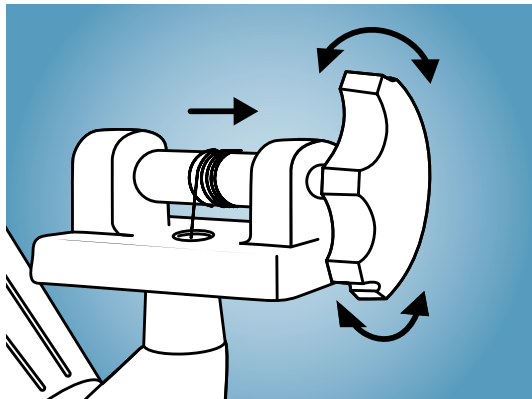

With the handle in the **two-way position**, slowly rotate the handle clockwise to wind the trigger cord onto the handle spool.

Note: Care must be exercised to avoid deploying a band while winding the trigger cord.

INSTRUCTIONS FOR LIGATION

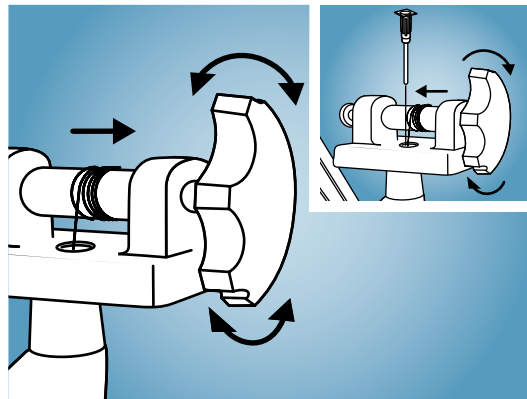

With handle in the **two-way position**, introduce the endoscope. **After intubation** place the handle in the **firing position**. Visualize the selected varix or hemorrhoid and aspirate into the Opti-Vu barrel. Maintain suction, deploy the band by rotating the ligator handle clockwise until band release is **felt**. If irrigation is necessary, insert irrigation adapter into the white seal of the handle.

SCOPE COMPATIBILITY

Order No.	Endoscope Outer Diameter
MBL-U-4	8.6 mm - 11.3 mm
MBL-U-6	8.6 mm - 11.3 mm
MBL-U-10	8.6 mm - 11.3 mm
MBL-6-OV	9.5 mm - 11.5 mm
MBL-6-OV-XS	8.6 mm - 9.2 mm
MBL-4	9.5 mm - 13 mm
MBL-6	9.5 mm - 13 mm
MBL-10	9.5 mm - 11.5 mm
MBL-4-XS	8.6 mm - 9.2 mm
MBL-6-XS	8.6 mm - 9.2 mm
MBL-10-XS	8.6 mm - 9.2 mm
MBL-4-XL	11 mm - 14 mm
MBL-6-XL	11 mm - 14 mm
MBL-4-XL-C	11 mm - 14 mm
MBL-6-XL-C	11 mm - 14 mm

LIGATION OF INTERNAL HEMORRHOIDS STEP 1

Lubricate the endoscope and exterior portion of the assembled Opti-Vu barrel. With the Multi-Band Ligator handle in the **two-way position**, introduce the endoscope into the rectum.

STEP 2

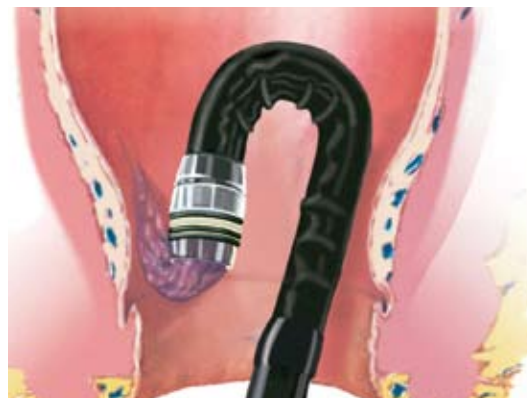

Retroflex the endoscope to visualize the selected internal hemorrhoid. **After** retroflexion, place the handle in the firing position. Aspirate the internal hemorrhoid into the Opti-Vu barrel. **Caution:** Ligation should only be performed on internal hemorrhoids located above the dentate line. Maintain suction on the internal hemorrhoid and deploy the band by rotating the ligator handle clockwise until band release is **felt**, indicating deployment.

STEP 3



Release the suction button of the endoscope, insufflate air, then advance the endoscope slightly to release the ligated hemorrhoid. **Caution:** Ensure the Opti-Vu barrel is advanced onto the tip of the endoscope as far as possible. Failure to do so may result in barrel dislodgement. Repeat the ligation process as needed.

Refer to current instructions for detailed system use.



COOK ENDOSCOPY
4900 Bethania Station Road, Winston-Salem, NC 27105 U.S.A.
Phone: 336 744-0157, Toll Free: (USA) 800 457-4500, Fax: 336 744-5231
4, 6, 10 Shooter is a trademark of Cook Endoscopy.
Opti-Vu is a registered trademark of Cook Endoscopy.
Cook is a registered trademark of Cook Incorporated.

www.cookmedical.com © 2008 Cook Medical